



  
JAGUAR

***I-PACE***  
MEDIA INFORMATION



CONTENTS

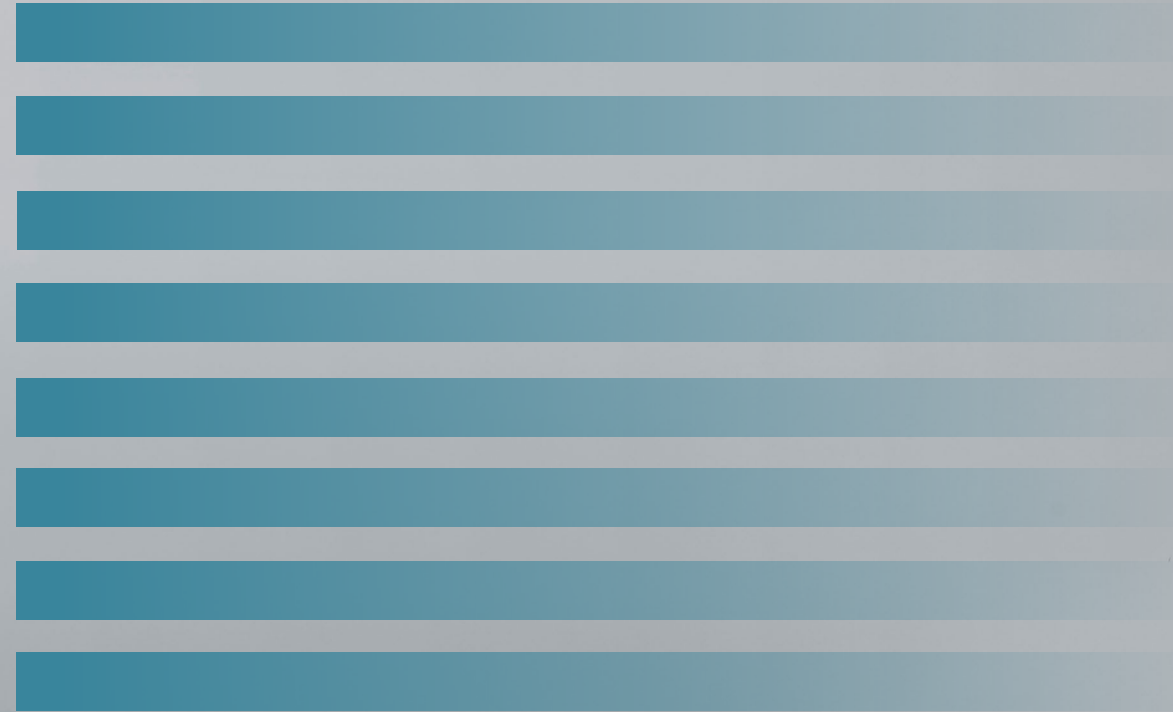



“

W

*hen we developed the I-PACE we wanted it to be the world's most desirable EV and show what happens when Jaguar goes electric. I think we've achieved those ambitious goals, and now we've made it even better with a new infotainment system, three-phase charging and technology that enriches the driving experience and occupant wellbeing.”*

**ALAN VOLKAERTS**

VEHICLE LINE DIRECTOR, JAGUAR I-PACE





01  
>

## AT A GLANCE



- **All-electric I-PACE performance SUV:**  
 now featuring a new infotainment system, three-phase AC home charging and even more driver-focused technology
- **Pivi Pro infotainment system:**  
 as quick and easy to use as your smartphone, with self-learning navigation that can show you where the nearest available charge station is, how much it will cost and how long it will take to charge
- **Faster home charging:**  
 11kW (AC) domestic wall box can add 53km/33miles of range (WLTP) per hour for customers with three-phase supplies
- **Outstanding performance and range:**  
 Acceleration from 0-60mph in just 4.5 (0-100km/h 4.8 seconds) seconds and up to 470km/292 miles (WLTP)
- **Greater connectivity:**  
 Dual-modem embedded SIM with 4G data plan, wireless device charging, embedded Spotify, and Bluetooth for two phones at the same time
- **Driver Assistance Technology:**  
 A new 3D surround camera and ClearSight rear view digital mirror deliver unimpeded visibility
- **Occupant wellbeing enhanced:**  
 Cabin air ionisation with PM2.5 filtration captures ultrafine particles and allergens. The I-PACE can filter cabin air while on charge before a journey
- **More distinctive design:**  
 Atlas Chrome finish to grille pins as standard, enhanced paint palette and introduction of a 19-inch wheel
- **New Bright Pack option:**  
 accentuates I-PACE's World Car of the Year award-winning design
- **Enhanced software-over-the-air capability:**  
 Systems including infotainment, battery management and charging can be updated remotely and enable the I-PACE to continuously improve over time



The Jaguar I-PACE – the world’s first premium all-electric performance SUV – now offers a new fast, intuitive infotainment system and quicker home charging capability, making owning and driving an electric vehicle easier than ever





---

## OVER 80 JAGUAR I-PACE AWARDS

---

Since its debut the I-PACE has won more than 80 global awards, including 2019 World Car of the Year, World Car Design of the Year and World Green Car, reinforcing its status as the Jaguar which tore up the rule book to become the first and best electric car of its kind.





02  
>

# ELECTRIC



**W**ith a state-of-the-art 90kWh Lithium-ion battery using 432 pouch cells, the I-PACE delivers a range of up to 470km (WLTP).

I-PACE now comes with an 11kW on-board charger as standard, enabling customers with access to three-phase electricity supplies to enjoy significantly faster charging: when connected to an 11kW wall box 53km/33 miles\* of range (WLTP) per hour can be achieved, while a full charge from empty now takes only 8.6 hours – ideal for overnight charging at home. Customers in single-phase markets using 7kW wallboxes also benefit from competitive charging capability – up to 35km/22 miles of charge per hour, with a full charge taking 12.75 hours.

When charging 'on the go', a 50kW DC charger will add up to 63km/39 miles in 15 minutes, whilst a 100kW charger will add up to 127km/78 miles over the same period.

**A suite of smart range-optimising technologies includes a battery pre-conditioning system: when plugged in the I-PACE will automatically raise (or lower) the temperature of its battery to maximise range ahead of driving away.**

\*Range added per one-hour/15-minute period is WLTP range



**15  
minutes**

CHARGING AT 100KW  
DC GIVES UP TO 127KM  
EXTRA RANGE (WLTP)



**11kW  
Charger**

CHARGING AT 11KW AC  
GIVES UP TO 53KM EXTRA  
RANGE PER HOUR (WLTP)

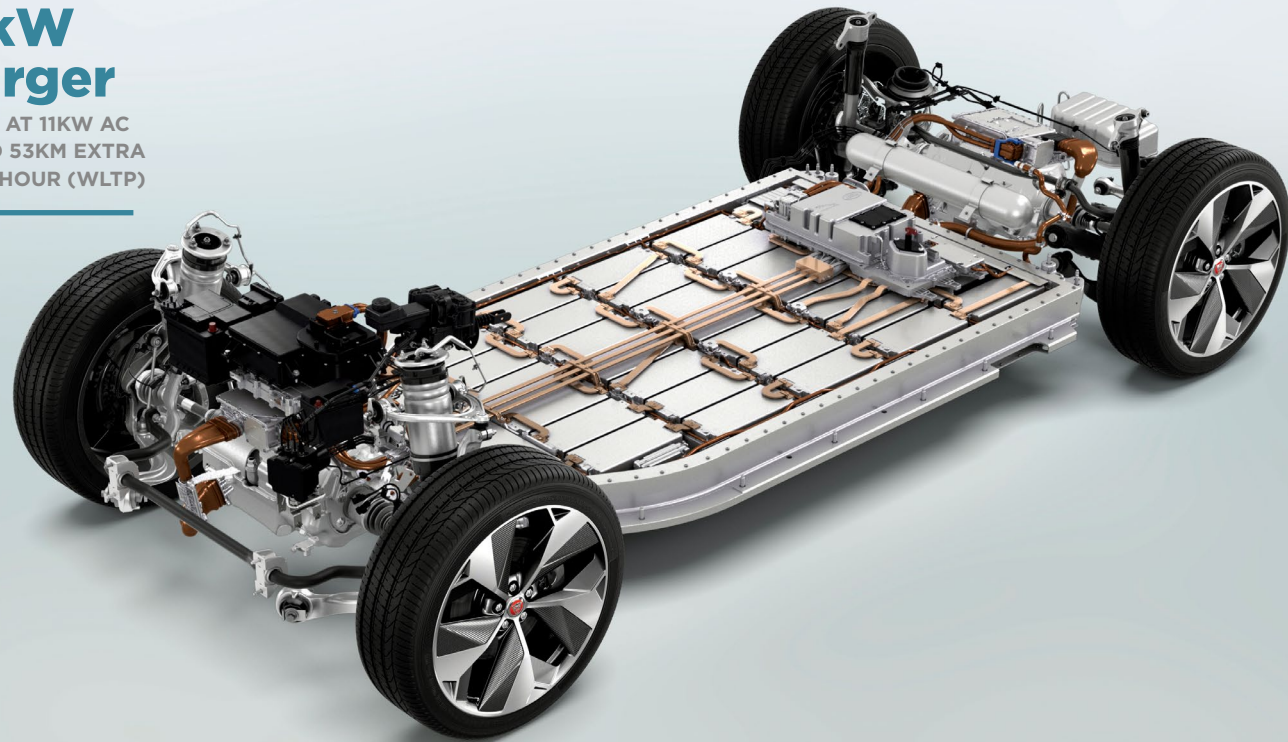



03  
▼

# PERFORMANCE



**T**wo Jaguar-designed electric motors - which feature driveshafts passing through the motors themselves for compactness - are placed at each axle, producing exceptional combined performance of 400PS and 696Nm, and all-wheel-drive, all-surface traction.

The high torque density and high-energy efficiency characteristics of the motors deliver sports car performance,

launching the I-PACE from a standing start to 60mph in just 4.5 seconds. The instantaneous performance is matched with exceptional ride comfort and engaging driving dynamics.

The bespoke EV aluminium architecture uses advanced riveting and bonding technology to deliver a light, stiff body structure. Together with the structural battery pack, it has a torsional rigidity of 36kNm/° - the highest of any Jaguar.

The battery is placed centrally between the two axles, and as low down as possible, with a seal between the housing and the underfloor. This location enables perfect 50:50 weight distribution and a low centre of gravity: together with the advanced double wishbone front and Integral Link rear axle with (optional) air suspension and configurable Adaptive Dynamics, this delivers agile handling and outstanding ride comfort.







**4.8s**  
0-100km/h



**400PS**  
POWER



**696Nm**  
TORQUE



# Electric Performance

## JAGUAR I-PACE KEY FACTS

### 90kWh BATTERY

The battery is made up of 432 high energy density, Lithium-ion pouch cells, arranged in 36 modules of 12: the best technology to deliver maximum range, performance and efficiency



### SINGLE-PEDAL DRIVING

The I-PACE's sophisticated braking system provides regenerative charging power to the battery in all driving modes - maximising range. And, by selecting the 'high' regenerative mode, it enables intuitive 'single pedal' driving in many conditions. Regenerative braking can produce up to 0.4G of braking force

UP TO  
**470km**  
(292 miles)  
RANGE ON THE WLTP TEST CYCLE

### 100kW DC RAPID CHARGING

15 MINUTES CHARGING AT 100kW DC GIVES UP TO 127KM (78 MILES) EXTRA RANGE



### TWO ELECTRIC MOTORS

The Synchronous Permanent Magnet motors are light and extremely efficient. Packaging them concentrically with the single-speed transmissions makes them as compact as possible. Their position on each axle delivers all-wheel drive and, together with the underfloor battery, contribute to I-PACE's low centre of gravity to enhance control, handling and agility



### 36kNm/° TORSIONAL RIGIDITY

The integral battery structure means I-PACE is the stiffest vehicle in the Jaguar range - optimising handling agility and safety

### 11KW WALL BOX

Charges the battery from 0-100% in 8.6 hours - ideal for overnight charging at home

**696Nm** TORQUE | **4.5s** 0-60mph | **400PS** POWER



04  
>

## DESIGN



**R**ecognised as the 2019 World Car Design of the Year, there is nothing else on the road that looks or drives like the Jaguar I-PACE. It is designed and engineered to take full advantage of its smart electric powertrain and maximise the potential of the packaging benefits it brings.





## ENHANCED CUSTOMER CHOICE



**T**he I-PACE's exterior design is enhanced with a new Atlas Grey grille tip finish and a new luxurious Bright Pack option, available on all models in the range. The Bright Pack accentuates I-PACE's breath-taking design with a Noble Chrome grille surround, Atlas Grey door mirror caps, Satin Chrome window surrounds and Atlas Grey for the rear diffuser. The contemporary Black Pack option is enhanced with the application of the gloss black finish to the rear badges (as pictured in Indus Silver to the left).

A refreshed paint palette now features colours such as Caldera Red, Portofino Blue and Eiger Grey. There's also a wider choice of wheels, with a new 19-inch design being offered for the first time on I-PACE, and replacing 18-inch wheels as standard equipment on S models in select markets.





Inside, the layout optimises space for passengers while sophisticated materials – including the option of a premium textile Kvadrat interior – and exquisite attention to detail identify this as a true Jaguar.

While a mid-sized SUV, I-PACE's cab forward design and EV powertrain means interior space comparable to large SUVs. In the rear, legroom is 890mm while, with no transmission tunnel, there's a useful 10.5-litre central storage compartment. In the rear, tablet and laptop stowage is found beneath the seats, while the rear luggage compartment offers a 656-litre capacity – and 1,453 litres with seats folded flat.

Customers can now benefit from the option of an enhanced Meridian 3D Surround Sound System with Trifield™ technology. The system features two additional speakers in the cabin headliner, meaning the 16 speaker and one subwoofer arrangement delivers an exceptional experience for all occupants.'

**10.5-litre**  
CENTRAL STORAGE  
COMPARTMENT



**890mm**  
REAR LEGROOM





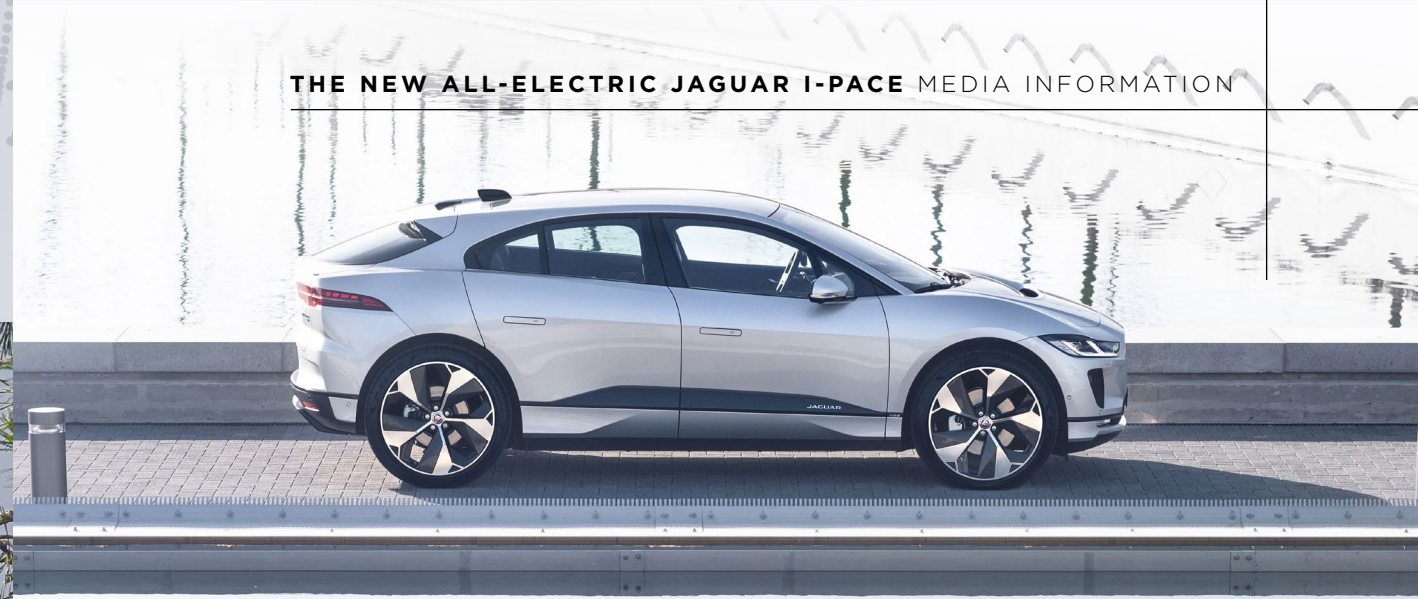



# Wired for Life

## JAGUAR I-PACE KEY FACTS

### PIVI PRO



The new Pivi Pro infotainment system is designed around you. As quick and easy to use as your smartphone, its self-learning technology means the settings are tuned to your preferences. The navigation will show you where the nearest available charge station is, how much it will cost and how long it will take to charge whilst Pivi Pro's AI can automatically activate certain comfort features, suggest media sources or who to call based on your routines. It can even remind you if you've forgotten your phone

### BATTERY PRE-CONDITIONING



Prepare for a journey using the Remote app to pre-heat or cool the cabin and battery while plugged-in, using zero battery power and maximising range

### SMART CHARGING

Pre-set home charging times to match best electricity tariffs



### ECO MODE

Enables extended range by turning off non-essential systems

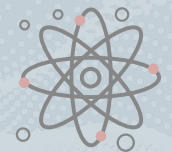

### CABIN AIR IONISATION

Now with PM2.5 filtration to capture ultrafine particles and allergens. The I-PACE can even filter its cabin air before a journey begins

### DRIVER ASSISTANCE TECHNOLOGY

A new 3D 360° surround camera and ClearSight rear-view digital mirror deliver unimpeded visibility for the driver

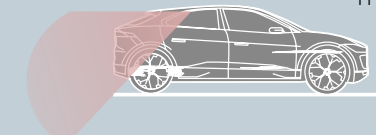

### SOFTWARE OVER-THE-AIR

Wireless software updates to the infotainment and vehicle systems means I-PACE continuously improves over time



### 4G WI-FI HOTSPOT

for up to eight devices with 20GB data included per month\*



\*Dependant on market availability and subject to a fair use policy where the Hotspot option has been selected



05  
v5

# PIVI PRO - SMARTER, FASTER AND BETTER CONNECTED



**T**he new Pivi Pro infotainment system is a highlight of the I-PACE's spacious, luxurious interior. The 12.3-inch high-definition virtual instrument cluster, 10-inch and 5-inch upper and lower touchscreens\*\* and multi-function, haptic rotary controllers are matched to crisp, clean, contemporary graphics for an engaging, intuitive user experience.

Inspired by smartphones, Pivi Pro is easy to use, while its powerful processor and 'fast start-up' ensures the system is ready to go by the time you're in the driving seat. Supported by a built-in back-up battery, navigation initialisation takes just a few seconds.

The new and intuitive flat menu structure makes navigating the system easy with the features and functions you use regularly

accessible via the home screen with just a click. The redesigned navigation system reduces the number of steps required to set a destination by half, and customers are now able to pan and zoom in and out of the map with a pinch of the fingers, just as with a smartphone.

\*\*The lower touchscreen is an option on the 'S' model and standard on all others



I-PACE is now available with an optional wireless device charging pad beneath the 'floating' centre console. Wireless charging also includes signal boosting, ensuring the phone's signal remains stronger for longer. A Smartphone Pack with Apple CarPlay® is standard, as is Bluetooth technology which can pair two phones simultaneously ensuring you'll always be connected. The Smartphone Pack also includes Android Auto™ and Baidu CarLife, depending on market applicability, as standard.

Customers need no longer be concerned about data usage or buying a SIM, as the I-PACE comes with a dual modem embedded SIM (eSIM) and complimentary 4G data plan which enables unlimited music streaming via Spotify, Deezer or Tunin and map, weather, calendar and traffic updates simultaneously\*\*\*.

\*\*\*4G data plan is subject to market availability. The unlimited data is provided by the eSIM and applies to connected services and features for their respective subscription periods: Connected Navigation is initially included for three years and the Online Pack connected services subscription is provided for an initial period of one year

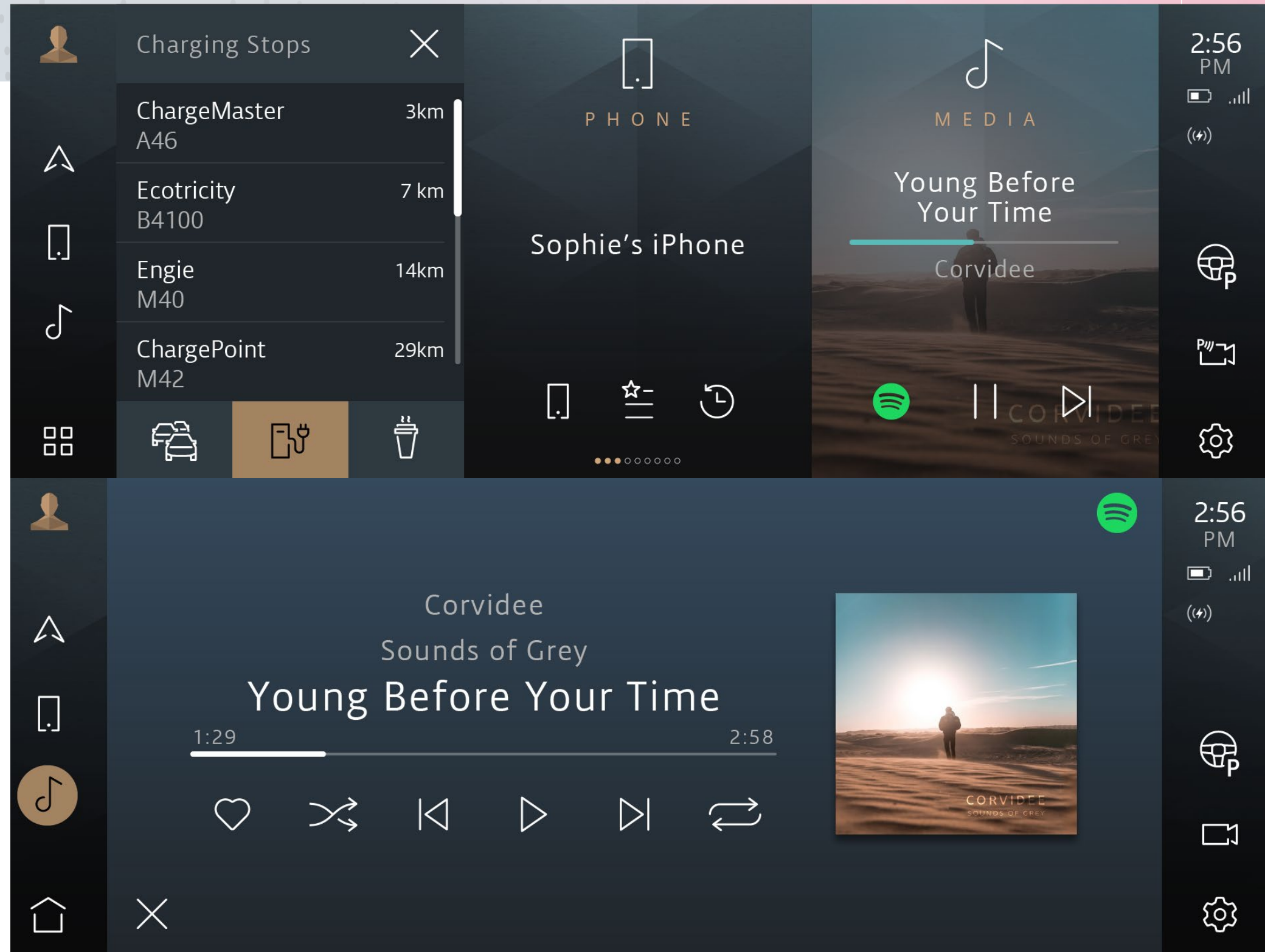



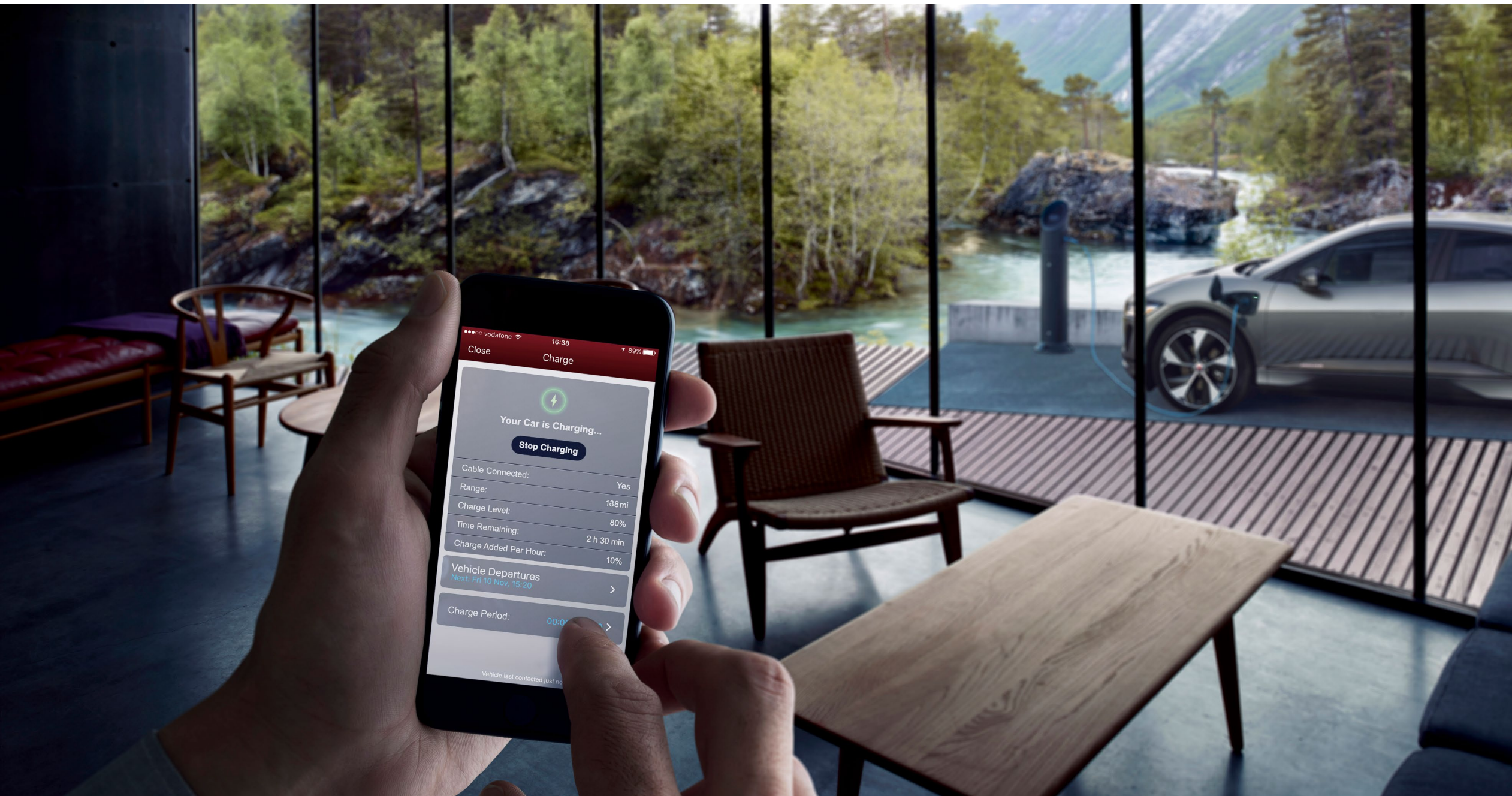

The new Pivi Pro infotainment will help to get you where you want to go in less time and with less effort. The navigation uses self-learning algorithms to optimise routing, voice guidance and even knows to remain quiet when you're travelling through areas you know, and maps will always be up to date thanks to software-over-the-air (SOTA) functionality.

Simplifying the process still further is Pivi Pro's ability to automatically add charging stations to your route, if needed. The system will select the optimum chargers to minimise total journey time. On long drives, Pivi Pro can also show you the predicted charge level on arrival at each waypoint\*\*\*\*.

\*\*\*\*Navigation features will continue to be enhanced via software-over-the air updates



# PIVI Pro

SMARTER,  
FASTER,  
BETTER  
CONNECTED  
INFOTAINMENT

## READY WHEN YOU ARE

The system enables within seconds of unlocking, so Pivi Pro is ready by the time you're in the driving seat

## INTUITIVE OPERATION

Pivi Pro is designed like your smartphone - its intuitive menu structure makes everything quick and easy to find

## ACCESS ALL AREAS

Your favourite and most frequently used features can be accessed with one click from the home screen. Two clicks will get you access to most other features

## ALL-NEW CONNECTED NAVIGATION

Cloud connectivity and machine learning make every journey easier. Online Routing and live traffic Information synchs with Dynamic Routing capability to keep you on the fastest route available, while the voice guidance automatically mutes when you're driving along the roads you know

## PUBLIC CHARGING MADE SIMPLE

PIVI PRO highlights charging station locations, availability, cost and estimated charge time<sup>1</sup>. It will also add charging stations to your route where the battery charge is predicted to be low<sup>2</sup>

## FUTURE-PROOFED

Enhanced software-over-the-air (SOTA) capability means that maps automatically update in the background. SOTA also enables new features to be added, ensuring your infotainment experience improves over time

## ORGANISED AND ON-TIME

Link your Microsoft or Google Calendar to your car and see what your day ahead looks like. Appointments including addresses will be transferred automatically to your Navigation system from the home screen

## SEAMLESS CONNECTIVITY

Apple CarPlay is standard. As is Android Auto and Baidu Car Life<sup>3</sup>

## EMBEDDED SPOTIFY

A fully integrated Spotify experience, provides customers with unlimited music streaming and instant access to more than 50 million tracks and more than 700 thousand podcasts - without having to connect a phone. Deezer and TuneIn embedded apps are also provided<sup>4</sup>

## COMES WITH DATA

With an integrated eSIM, enjoy all the data you need to keep you connected without the need for a contract or a separate SIM card<sup>5</sup>

## CELLULAR INTERNET

connectivity can roam across multiple network providers to maximise signal coverage

## MAKE THE RIGHT CALL

Pivi Pro can connect two phones via Bluetooth at the same time allowing either phone to be answered safely whilst driving

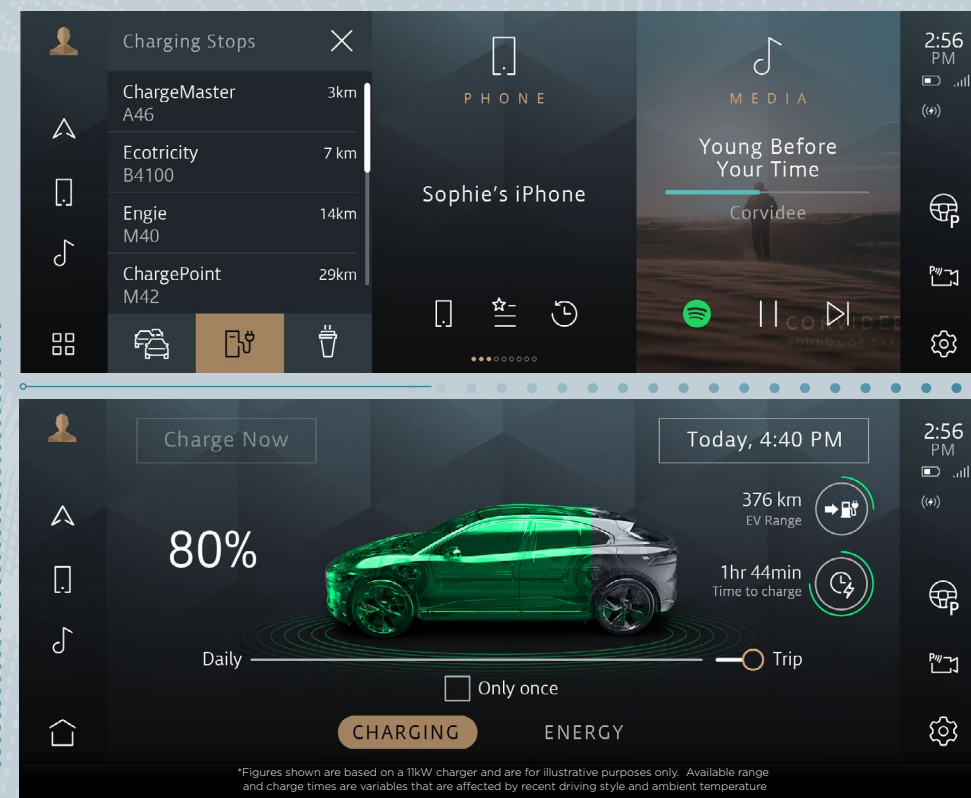

\*Figures shown are based on a 11kW charger and are for illustrative purposes only. Available range and charge times are variables that are affected by recent driving style and ambient temperature

<sup>1</sup> Where supported

<sup>2</sup> Navigation features will continue to be enhanced via software-over-the-air updates

<sup>3</sup> Dependant on market availability

<sup>4</sup> Spotify Premium subscription required

<sup>5</sup> Unlimited data is provided by the eSIM and applies to connected services and features for their respective subscription periods



“

T

*he Pivi Pro infotainment system makes it easy to use public charging networks. As well as showing where charging stations are it can also tell you if they're available, what they cost to use, and an estimate of charging time. We know that most customers charge their I-PACE at home but we wanted to make charging on the go just as simple – and our new infotainment system makes that possible.”*

**STEPHEN BOULTER**

VEHICLE ENGINEERING MANAGER, JAGUAR I-PACE









06  
v

# DRIVER ASSISTANCE & WELLBEING

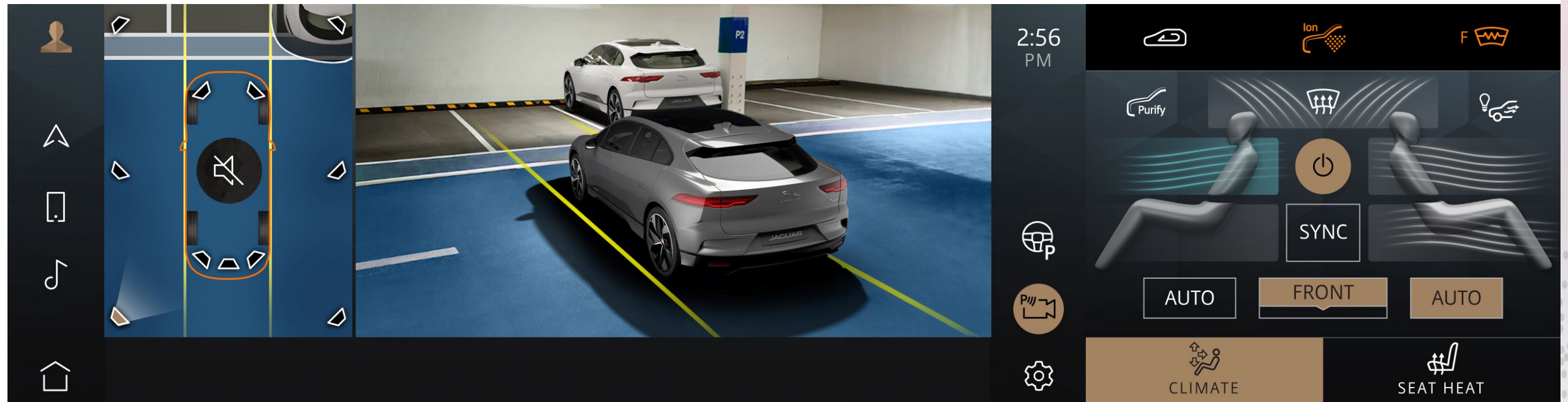

**T**he I-PACE has been designed to keep you and your family safe, and was awarded the maximum five-star EuroNCAP rating.

State-of-the-art digital technology further assists drivers and road users. Visibility is significantly enhanced with a new 3D Surround Camera that provides a 360-degree digital plan view of the surrounding

area and potential hazards, visible through the central touchscreen.

Inside the cabin, the ClearSight rear view mirror improves vision and convenience by ensuring the driver always has an unobstructed view of the road behind, even with three people in the rear seat or with the 656-litre luggage compartment loaded up to the roof.

ClearSight uses a wide-angle, rear-facing camera linked to a high-resolution screen within the frameless glass mirror. A small toggle switch on the mirror allows the driver to switch seamlessly between the view from the standard mirror and the camera feed.

Neatly integrated within the roof-mounted antenna module, the high-definition camera works in all

conditions, including low ambient light, while a protective lip and hydrophobic coating help to repel water and ensure the camera lens remains as clean as possible.

All occupants benefit from the enhanced climate control system, which delivers smart, energy-efficient heating or cooling of up to four zones independently. Cabin air ionisation designed to remove allergens,

also features a filtration system which captures ultrafine particles – including PM2.5 particulates – to improve occupant health and wellbeing. One important benefit to the new filtration system is that, when charging, customers can use the I-PACE's pre-conditioning system (which optimises battery temperature) to also purge the cabin of allergens and ultrafine particles before beginning a journey.







07  
>

# GOING ELECTRIC MADE EASY



The Jaguar I-PACE has been designed to ensure every step of the customer journey delivers peace of mind and makes owning an electric car as easy as possible.

- ▣ With a range of up to 470km/292 miles (WLTP) from its 90kWh battery, customers with an average daily commute would only need to charge their I-PACE once a week
- ▣ I-PACE is offered with an 8 year or 100,000 mile/160,000km battery warranty
- ▣ A range calculation tool on jaguar.com makes it easy to see how factors such as vehicle speed, ambient temperature and climate control settings can influence the real-world range you could expect to achieve
- ▣ Jaguar has developed the iGuide app making it simple to find and understand the key features and controls of your Jaguar I-PACE. It also doubles as your mobile owner's manual, ensuring the answer to any question about charging are at your fingertips
- ▣ For queries 'on the go', I-PACE customers can also get help 24/7 from the I-Assistance service - at the touch of a button they'll be connected directly to an expert to answer any queries about the vehicle
- ▣ Jaguar partners with home-charging providers all over the world, making charging your car as easy as charging your phone
- ▣ Every home charging point from Jaguar's recommended partners comes smart enabled, meaning you can conveniently activate and deactivate your charging progress straight from your smart phone
- ▣ When charging in public places, the I-PACE's charging cable locks into place as soon as the car is locked, and cannot be disconnected until the vehicle is unlocked, giving you the freedom to go about your day while the vehicle charges up
- ▣ The Jaguar I-PACE has an Eco Mode which helps preserve range by reducing energy depletion and encouraging a more efficient driving style. It also makes subtle changes to cabin temperature, air recirculation and to a number of the car's other features. You can override these changes by normal operation of each feature or via the menu settings
- ▣ The I-PACE is equipped with Software over the Air (SOTA) functionality. This means Systems including infotainment, battery management and charging can be updated remotely and enable the I-PACE to continuously improve over time



# Electric Living

## JAGUAR I-PACE KEY FACTS



### INFRARED ABSORPTION

The full-length panoramic roof absorbs UV light so there's no need for a blind: it keeps the cabin cool and increases headroom

### DISCRETE STORAGE

Storage trays beneath the rear seats designed for laptops and tablets

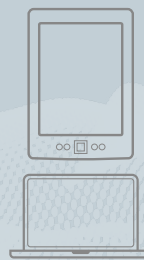

**656 LITRE**

Rear luggage compartment, 1,453 litres with second row seats down, with flat floor for easy loading and unloading

### DIGITAL SOUNDSCAPE

A meticulously tuned soundtrack works in harmony with the natural sound of the two electric motors, making the driving experience even more rewarding. In Dynamic mode the sound becomes richer still, reflecting I-PACE's driver-focused character



**4 12V SOCKETS**

**4 USB PORTS**

### ELECTRIC ADVANTAGES

Electrification and the cab-forward design deliver exceptional interior space within a compact footprint

### WIRELESS DEVICE CHARGING AND SIGNAL BOOST

High power wireless charger with phone signal boosting capability that helps to provide a stronger phone signal for longer

	HEADROOM	LEGGROOM
FRONT	1,013mm	1,040mm
REAR	968mm	890mm

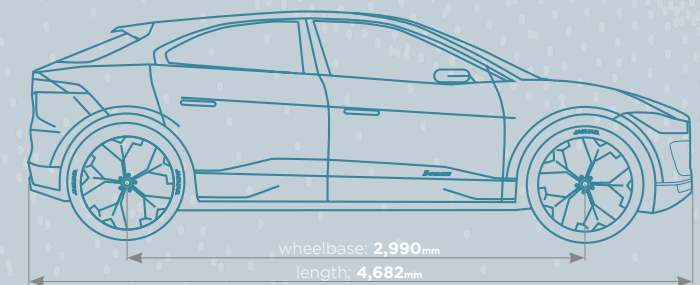



00  
v00

# TECHNICAL DATA

ELECTRIC MOTORS	EV400 (AWD)
Configuration	Two permanent magnet electric motors; synchronous Single-speed epicyclic transmission; concentric with motor
Power PS (kW)	200 / 147
Torque Nm (lb ft)	348 / 256
Total system power PS (kW)	400 / 294
Total system torque Nm (lb ft)	696 / 512
DRIVETRAIN	
Configuration	Motor and transmission integrated into front and rear axles; Electric all-wheel drive
BATTERY	
Configuration	90kWh Li-ion; liquid-cooled; pouch cells
Number of cells/ modules	432/ 36
Charging 0-100% on AC 7kW (hours)*	12.75
Range added per hour of charge on AC 7kW (km/miles)*	35 / 22
Charging 0-100% on AC 11kW three-phase (hours)*	8.6
Range added per hour of charge on AC 11kW three-phase (km/miles)*	53 / 33
Range added per 15 mins of charge - Rapid DC 50kW (km/miles)*	63 / 39
Range added per 15 mins of charge - Rapid DC 100kW (km/miles)*	127 / 78
*All range figures quoted are WLTP	
CHASSIS	
Front suspension	Double wishbone
Rear suspension	Integral Link
Front brake diameter (mm)	350 (Ventilated)
Rear brake diameter (mm)	325 (ventilated)
Springs	Air or coil
Dampers	Continuously-variable or passive
Steering	Rack-and-pinion; electromechanical
EXTERIOR DIMENSIONS	
Overall length (mm)	4,682
Overall height (mm)	1,565
Overall width (mirrors folded) (mm)	2,011
Overall width (mirrors unfolded) (mm)	2,139
Wheelbase (mm)	2,990
Front track (mm)	1,624 - 1,643
Rear track (mm)	1,647 - 1,663
INTERIOR DIMENSIONS	
Headroom (without sunroof) (mm)	994 (front)
Legroom (mm)	1,040 (max front legroom) / 890 (max rear legroom)
Luggage compartment volume (litres)	656 plus 27 (front)
WEIGHT	
Weight from (EU unladen) (kg)	From 2,208
Weight; DIN (kg)	From 2,133
PERFORMANCE	
0-60mph (0-96km/h) (secs)	4.5
0-62mph (0-100km/h) (secs)	4.8
Top speed mph (km/h)	124 / 200
Range (WLTP)	Up to 470km
1) Manufacturer's figures; correct at time of going to press	
2) View WLTP figures: <a href="http://jaguar.com/market-selector">jaguar.com/market-selector</a>	

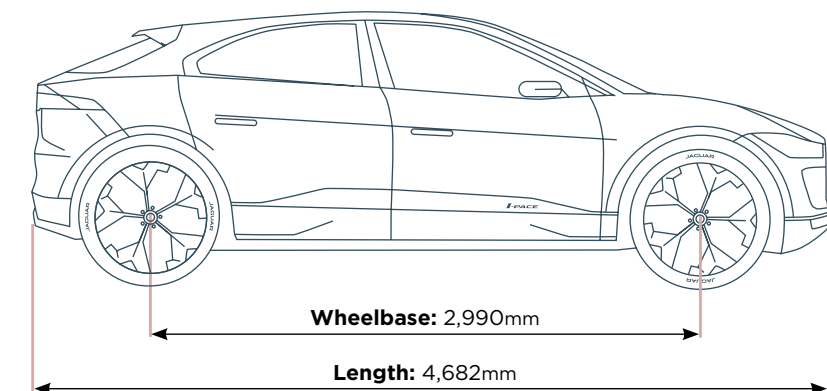
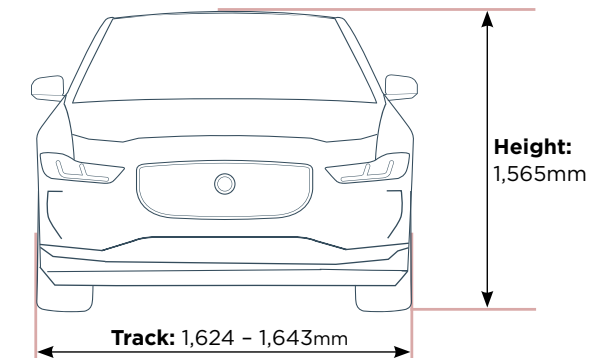

Overall width: 2,139mm

