



THE JAGUAR
F-TYPE

>01

**THE NEW F-TYPE
R-DYNAMIC BLACK**

ENHANCES THE BEAUTIFUL, TIMELESS DESIGN WITH ADDITIONAL EQUIPMENT AS STANDARD AND OFFERED IN COUPÉ AND CONVERTIBLE BODY STYLES

>03

**DRIVER-FOCUSED,
LUXURIOUS INTERIOR**

12-WAY WINDSOR LEATHER PERFORMANCE SEATS IN EBONY WITH LIGHT OYSTER STITCH OR MARS WITH FLAME RED STITCH AND AN EBONY SUEDECLOTH HEADLINER ENRICH THE UNIQUE '1+1' CABIN

>05

**ENRICHING THE
DRIVING EXPERIENCE**

12.3-INCH HD VIRTUAL INSTRUMENT CLUSTER, ENHANCED MERIDIAN AUDIO AND SMARTPHONE PACK WITH APPLE CARPLAY

>02

**EVEN MORE
DESIRABLE:**

BLACK PACK, 20-INCH GLOSS BLACK WHEELS, AND CHOICE OF SANTORINI BLACK, EIGER GREY OR FIRENZE RED METALLIC PAINT ACCENTUATE F-TYPE'S INHERENTLY DRAMATIC FORM

>04

**BEAUTIFUL
DETAILS:**

HERITAGE-INSPIRED MONOGRAM PATTERN USED FOR SEAT AND DOOR TRIM STITCHING AND EMBOSING OF THE SUEDECLOTH WRAP FOR THE INSTRUMENT CLUSTER

>06

**POWERFUL,
REFINED ENGINES**

300PS INGENIUM FOUR-CYLINDER AND 450PS SUPERCHARGED V8 WITH REAR- OR ALL-WHEEL DRIVE AND EIGHT-SPEED 'QUICKSHIFT' TRANSMISSIONS DELIVER ENGAGING, EXPLOITABLE PERFORMANCE AND OUTSTANDING DRIVER REWARD





>07

**QUICKSHIFT
TRANSMISSION**

METICULOUSLY RECALIBRATED FOR P450 AND R MODELS TO OFFER EVEN FASTER, CRISPER GEAR CHANGES USING LEARNING FROM THE 200MPH JAGUAR XE SV PROJECT 8

>08

**F-TYPE R WITH 575PS
SUPERCHARGED V8**

FOR 0-60MPH IN JUST 3.5 SECONDS, AND AN UPRATED CHASSIS WITH NEW DAMPERS, ANTI-ROLL BARS, REAR KNUCKLES AND WIDER TYRES



AVAILABLE TO ORDER NOW AT JAGUAR.COM AND PRICED FROM

£54,925

[CORE F-TYPE RANGE]

AND

£64,455

[R-DYNAMIC BLACK MODELS]

IN THE UK

INTRODUCING THE F-TYPE R-DYNAMIC BLACK



With the introduction of the new Jaguar F-TYPE R-Dynamic

Black models, the perfectly proportioned and extraordinarily beautiful F-TYPE is now more distinctive than ever.

New R-Dynamic Black models further heighten the purity and presence that set Jaguar's definitive sports car apart. Developed from the 300PS four-cylinder and 450PS V8 RDynamic Coupé and Convertible*, these exclusive additions to the line-up offer an enhanced specification and an even more luxurious, crafted interior.

F-TYPE's pure, sculpted form is accentuated by the Black Pack and 20-inch, five split-spoke wheels with gloss black finish. Known as 'Style 5039', these wheels are not available on any other model in the range. Complementing these perfectly is the choice of three metallic paints: Santorini Black, Eiger Grey or Firenze Red.

The driver-focused '1+1' cabin surrounds the occupants with rich, luxurious materials. The slimline Performance Seats feature 12-way adjustment and are trimmed in Windsor leather with a choice of Ebony with Light Oyster contrast stitching or - for a more sporting theme - Mars with Flame Red stitch.

Details such as the beautifully crafted monogram stitch pattern, repeated in the door trim, are among the subtle refinements which make F-TYPE feel special.

The driver-focussed interior, like the exterior, has evolved into a purer expression of the car's elegance and performance. By concentrating on further refining the traditionally British Jaguar craftsmanship and adding discreet, beautiful details, the sense of luxury and sportiness has been heightened.

The same monogram design is used to emboss the suedecloth wrap for the 12.3-inch reconfigurable Interactive

Driver Display, while other refinements include satin-finish aluminium gearshift paddles, an Ebony suedecloth headliner and illuminated treadplates featuring the Jaguar script.

Julian Thomson, Design Director, Jaguar, said: Creating the new F-TYPE R-Dynamic Black models gave us the opportunity to subtly enhance the way the car looks - inside and out - and at the same time amplify both the luxury and sporting elements of its character. The result is an even more purposeful, focused, distinctive design with real presence, whether you choose the Coupé or Convertible, the four-cylinder or the V8."

The F-TYPE R-Dynamic Black's powerful, refined and responsive engines are matched to eight-speed Quickshift transmissions with full manual control using either the SportShift gear selector or the gearshift paddles.

Exclusively rear-wheel drive, the 300PS, 2.0-litre turbocharged Ingenium four-cylinder engine generates maximum torque from just 1,500rpm, delivering exceptional throttle response throughout the rev range. It also provides the performance expected from F-TYPE and enables acceleration from 0-60mph in only 5.4 seconds and a top speed of 155mph.

The 450PS, 5.0-litre supercharged V8 has been developed to offer exploitable, useable and rewarding performance - maximum torque of 580Nm is generated from 2,500rpm. It is offered with a choice of all-wheel drive with Intelligent Driveline Dynamics or - for purists - rear-wheel drive.

Both 450PS powertrains feature an electronic active rear differential to optimise traction, and both enable 0-60mph in just 4.4 seconds and a maximum speed of 177mph.



“

DESIGN THE MOST BEAUTIFUL SPORTS CAR, WITH PURITY, PROPORTION AND PRESENCE THAT'S UNMISTAKABLY JAGUAR: THAT WAS THE CHALLENGE WE SET OURSELVES. THE NEW F-TYPE IS MORE DRAMATIC THAN EVER AND EMBODIES TRUE JAGUAR DESIGN DNA.

”

JULIAN THOMSON
DESIGN DIRECTOR, JAGUAR

Significantly updated in 2020, the F-TYPE's award winning design has evolved with a focus on even greater purity and discipline to the perfectly-sculpted form. Super-slim pixel LED headlights* with subtly updated signature 'Calligraphy' J daytime running lights, and sweeping direction indicators, blend perfectly into the 'liquid metal' surfacing of the new clamshell bonnet, exaggerating the car's visual width and accentuating its assertive stance. The new front bumper and subtly enlarged grille deliver even more visual impact and presence.

The rear haunches enhance the F-TYPE's inherently dramatic, purposeful form, while the new slender rear lights combine an unmistakable LED chicane signature, introduced by the Jaguar I-PACE all-electric Performance SUV, with subtle monogram pattern detailing and a fine 'pinstripe' beneath.

The interior combines traditional Jaguar craftsmanship with rich, contemporary materials such as Windsor Leather and satin-finish Noble Chrome. Beautiful details include monogram stitch patterns in the seats and door trims, Jaguar Leaper motifs in the headrests, and subtle 'Jaguar Est.1935' markings on the centre console finisher, glovebox release button surround, and seatbelt guides.

The 12.3-inch reconfigurable HD TFT instrument cluster offers a choice of different displays, including full map mode but, as befits a true sports car, the default mode is characterised by the large central rev counter. This feature and the gearshift light subtly convey the F-TYPE's driver-focused character and performance potential.

Even before the drive begins, the F-TYPE delights the driver with the visual theatre of flush, deployable door handles and deployable air vents. Pressing the start button brings the car to life with its hallmark exhaust flare as purposeful as ever.

All engines – 300PS turbocharged four-cylinder, and 450PS and 575PS supercharged V8s – feature active exhaust systems, which are switchable either as an option or as standard. Customers who choose the V8 models benefit from the new Quiet Start function, which ensures a more subtle, refined sound – the electrically-actuated bypass valves in the rear silencer remain closed until they automatically open up under load. If desired, Quiet Start can be overridden by selecting Dynamic Mode or by pressing the switchable exhaust button before starting the engine.

The distinctive crackle and pop on the overrun synonymous with F-TYPE, remains, the sounds meticulously tuned to suit the range of powerful four-, and eight-cylinder engines. Highly efficient, close-coupled particulate filters reduce emissions.

Alan Volkaerts, Vehicle Line Director, Jaguar F-TYPE, said: "The F-TYPE is the definitive Jaguar sports car and continues to set the benchmark for design purity, driver engagement and reward, and a truly visceral driving experience – it makes every journey extraordinary.

"Its timeless looks are more assertive than ever, technologies such as the high-definition virtual instrument cluster deepen the driver-focused feel of the interior, while the range of powertrains offers a breadth of choice unrivalled in the

segment. Enthusiasts will appreciate the F-TYPE R's 575PS supercharged V8, enhanced chassis and intelligent all-wheel drive system, which deliver truly outstanding performance in all conditions while retaining its inherent tractability and usability."



The F-TYPE's driver-focused interior, like the exterior, has evolved into a purer expression of the car's elegance and performance. By concentrating on further refining the traditionally British Jaguar craftsmanship and adding discreet, beautiful details, the sense of luxury and sportiness has been heightened.

The 1+1 cockpit now features a 12.3-inch reconfigurable HD TFT instrument cluster, with graphics unique to F-TYPE. This offers a choice of display themes, including full map but, as befits a true sports car, the default mode is characterised by the large central rev-counter.

This feature and the gearshift light subtly convey the F-TYPE's character and performance potential, digitally enhancing the mechanical theatre of the pulsing red 'heartbeat' of the start button and the deployable air vents. The responsive, intuitive Touch Pro infotainment system's 10-inch touchscreen, matched to three tactile rotary controllers, offers the perfect balance of analogue and digital driver controls.

Lightweight slimline seats combine an ergonomically-optimised form with outstanding comfort, further enhanced by heating and cooling options. The seats come in two forms: Sport and Performance. The F-TYPE and F-TYPE R-Dynamic models come with the purest Sports version as standard. The Performance seat has more pronounced support at shoulder height, and is standard on the R and R-Dynamic Black models.



Rich materials such as Windsor leather add a further touch of luxury, complemented by details such as the beautifully-crafted monogram stitch pattern - repeated in the door trim - and Jaguar Leaper and R motifs in the headrests. The seat belt guides are finished with discreet 'Jaguar Est. 1935 markings', which are proudly repeated on the glovebox release button surround. This subtle reference signifies the year the Jaguar name was first used by company founder Sir William Lyons to brand one of his beautiful cars.

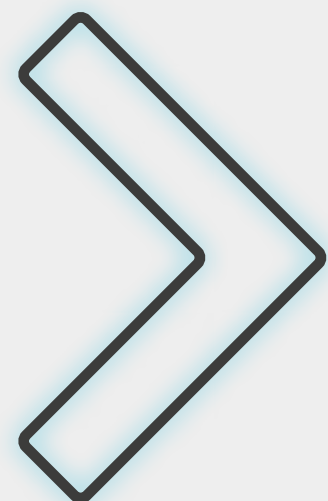



Raising the output of the all-wheel drive **F-TYPE R's** supercharged V8 to 575PS and 700Nm (up from 550PS and 680Nm respectively) delivers truly outstanding performance in all weathers and in all conditions, while retaining its inherent tractability and day-to-day usability. Performance is exceptional: the benchmark sprint to 60mph takes just 3.5 seconds, while maximum speed is an electronically-limited 186mph.

The F-TYPE R's increased power is matched to a comprehensively updated chassis with new, wider, 20-inch, 10-spoke wheels in Gloss Black with diamond-turned finish, and new adaptive dampers, springs, anti-roll bars and stiffer rear knuckles and ball joints, delivering even greater agility and responsiveness.

Taking all of the learning accrued from the development of the limited-edition, 200mph Jaguar XE SV Project 8, the Quickshift transmissions in both the F-TYPE R and the 450PS V8 models have been meticulously recalibrated for a more engaging driving experience. The F-TYPE R specifically offers even faster, crisper gear changes when the driver commands shifts manually via the steering wheel-mounted paddles or the SportShift gear selector. Both upshifts and downshifts are more immediate and give an even more connected and responsive feel.

The 450PS supercharged V8 has been developed to offer exploitable and rewarding performance - its maximum torque of 580Nm being generated from just 2,500rpm. It is offered with a choice of all-wheel drive and - for purists - rear-wheel drive. Both versions can accelerate from 0-60mph in just 4.4 seconds, and reach a maximum speed of 177mph.

Like the F-TYPE R, the 450PS V8 also gains stiffer rear knuckles to improve handling response. There's also an electronically-controlled rear differential to enhance traction.

The electronically-controlled dampers in the Adaptive Dynamics system have been tuned to deliver greater ride comfort, with the rear-wheel drive variant benefitting from unique calibration to optimise the ride and handling balance.

➤ F-TYPE TECHNICAL SPECIFICATION

ENGINE & TRANSMISSION	F-TYPE 300PS COUPÉ		F-TYPE 300PS CONVERTIBLE
Engine capacity (cc)			1,997
Cylinders			Four in-line turbocharged
Valves per cylinder			4; DOHC
Bore / stroke (mm)			83.0 / 92.3
Compression ratio			9.5:1
Power PS (kW)			300 (221) @ 5,500rpm
Torque Nm (lb ft)			400 (295) @ 1,500-4,500rpm
Transmission			8-speed Quickshift
CHASSIS			
Front suspension			Double wishbone
Rear suspension			Double wishbone
Front brakes			Single-piston sliding caliper; 355mm ventilated discs
Rear brakes			Single-piston sliding caliper; 325mm ventilated discs
Steering			Rack-and-pinion; electromechanical
DIMENSIONS & WEIGHTS			
Length (mm)			4,470
Width inc. / excl. mirrors (mm)			2,042 / 1,923
Height coupé / convertible (mm)			1,311 / 1,307
Wheelbase (mm)			2,622
Track front / rear (mm)			1,596 / 1,647
Weight; EU Unladen (kg)	1,628		1,646
Weight; DIN (kg)	1,553		1,571
Loadspace volume (litres)	299/509 with/without parcel tray		233
Fuel tank (useable) litres			63
PERFORMANCE & FUEL ECONOMY			
0-60mph (sec)	5.4		5.4
0-100km/h (sec)	5.7		5.7
Top speed mph (km/h)	155 (250)		155 (250)
Fuel consumption mpg (litres/100km) WLTP TEL/TEH Combined	29.7 (9.5) / 29.1 (9.7)		29.4 (9.6) / 28.8 (9.8)
CO ₂ emissions (g/km) WLTP TEL/TEH Combined	215 / 221		218 / 222

1) WLTP is the official EU test used to calculate standardised fuel consumption and CO₂ figures for passenger cars. It measures fuel, energy consumption, range and emissions. The figures provided are as a result of official manufacturer's tests in accordance with EU legislation. For comparison purposes only. Real world figures may differ. CO₂, fuel economy, energy consumption and range figures may vary according to factors such as driving styles, environmental conditions, load, wheel fitment and accessories fitted.
 2) Please check with your local market for features, model range and engine availability as they vary by market.
 3) Jaguar Land Rover is constantly seeking ways to improve the specification, design and production of its vehicles, parts and accessories and alterations take place continually. While every effort is made to produce up-to-date literature, this document should not be regarded as an infallible guide to current specifications or availability, nor does it constitute an offer for the sale of any particular vehicle, part or accessory. Figures are manufacturer's estimates.

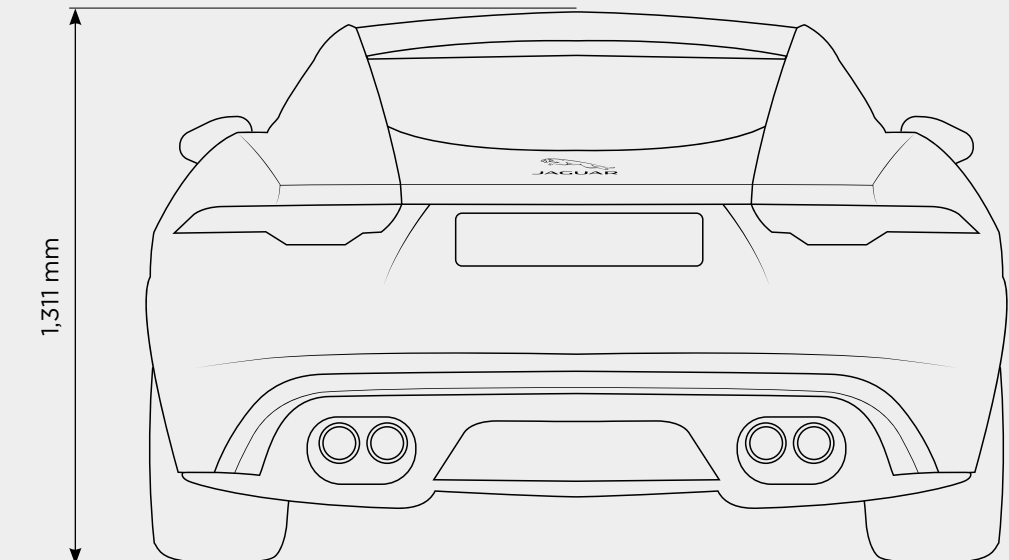
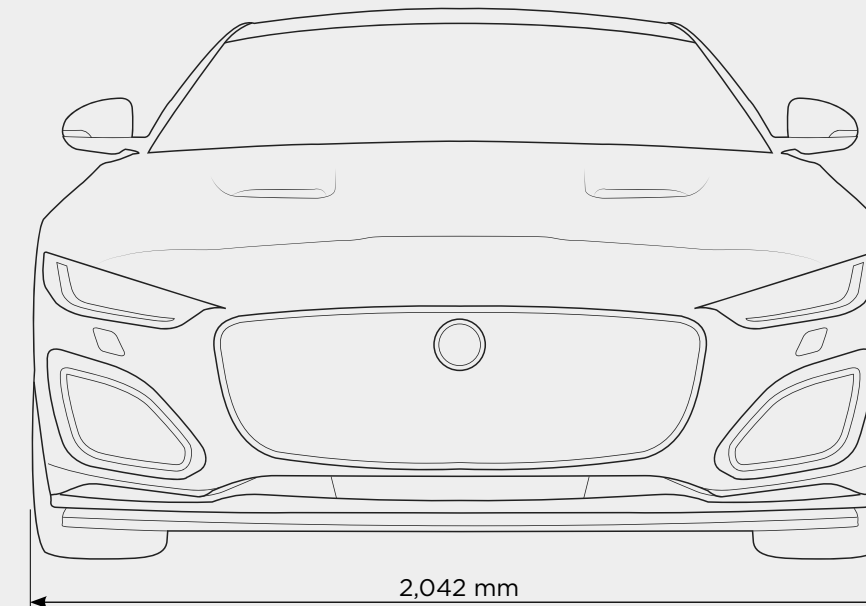
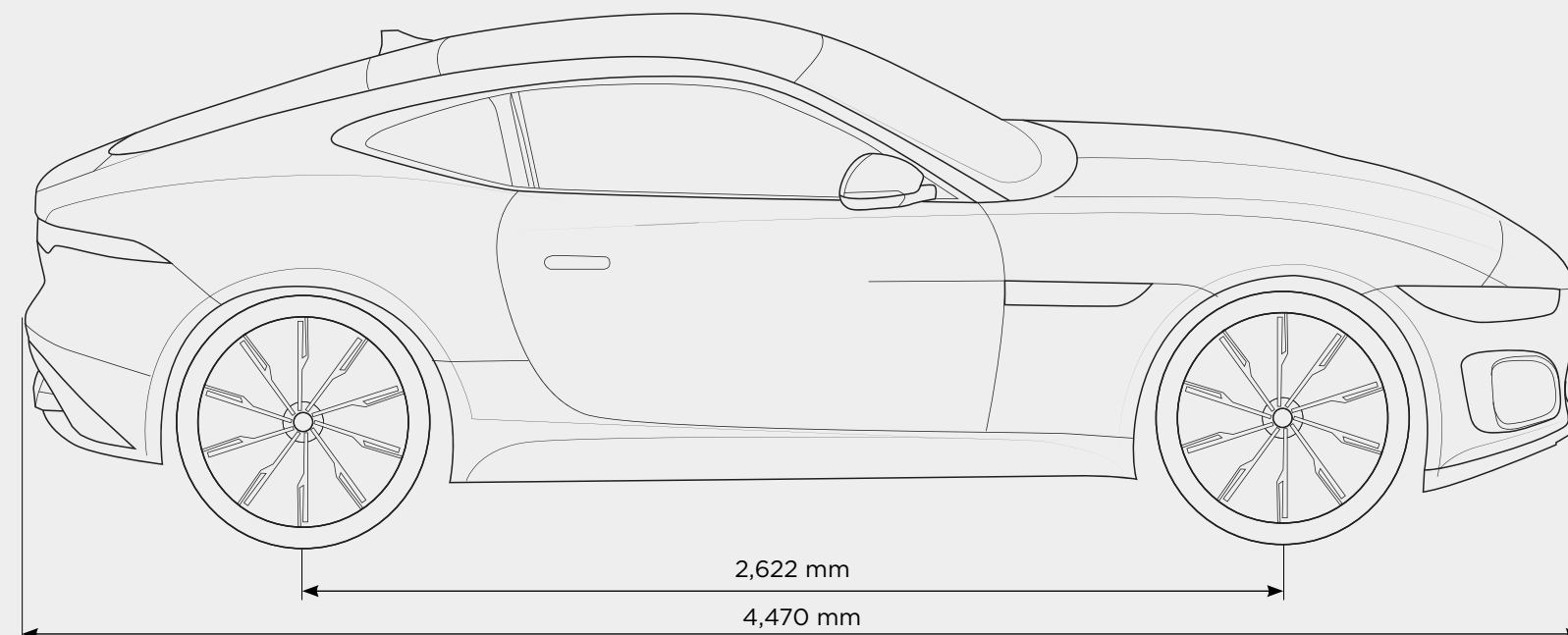

➤ F-TYPE TECHNICAL SPECIFICATION

ENGINE & TRANSMISSION	F-TYPE 450PS RWD COUPÉ	F-TYPE 450PS RWD CONVERTIBLE	F-TYPE 450PS AWD COUPÉ	F-TYPE 450PS AWD CONVERTIBLE	F-TYPE 575PS AWD COUPÉ	F-TYPE 575PS AWD CONVERTIBLE
Engine capacity (cc)	5,000				5,000	
Cylinders	V8 Supercharged				V8 Supercharged	
Valves per cylinder	4; DOHC				4; DOHC	
Bore / stroke (mm)	92.5 / 93.0				92.5 / 93.0	
Compression ratio	9.5:1				9.5:1	
Power PS (kW)	450 (331) @ 6,000rpm				575 (423) @ 6,500rpm	
Torque Nm (lb ft)	580 (428) @ 2,500-5,000rpm				700 (516) @ 3,500-5,000rpm	
Transmission	8-speed Quickshift					
CHASSIS						
Front suspension	Double wishbone					
Rear suspension	Double wishbone					
Front brakes	Twin-piston sliding caliper; 380mm ventilated discs					
Rear brakes	Single-piston sliding caliper; 376mm ventilated discs					
Steering	Rack-and-pinion; electromechanical					
DIMENSIONS & WEIGHTS						
Length (mm)	4,470					
Width inc. / excl. mirrors (mm)	2,042 / 1,923					
Height coupé / convertible (mm)	1,311 / 1,307					
Wheelbase (mm)	2,622					
Track front / rear (mm)	1,584 / 1,628					
Weight; EU Unladen (kg)	1,781	1,793	1,855	1,865	1,855	1,865
Weight; DIN (kg)	1,706	1,718	1,780	1,790	1,780	1,790
Loadspace volume (litres)	299/509 with/without parcel tray	233	299/509 with/without parcel tray	233	299/509 with/without parcel tray	233
Fuel tank (useable) litres	70					
PERFORMANCE & FUEL ECONOMY						
0-60mph (sec)	4.4		4.4		3.5	
0-100km/h (sec)	4.6		4.6		3.7	
Top speed mph (km/h)	177 (285)		177 (285)		186 (300)	
Fuel consumption mpg (litres/100km) WLTP TEL/TEH Combined	26.9 (10.5) / 26.2 (10.8)	26.4 (10.7) / 26.2 (10.8)	26.2 (10.8) / 25.7 (11.0)	26.2 (10.8) / 25.9 (10.9)	n/a / 26.4 (10.7)	n/a / 26.4 (10.7)
CO ₂ emissions (g/km) WLTP TEL/TEH Combined	239 / 244	242 / 245	246 / 249	246 / 248	n/a / 243	n/a / 243

1) WLTP is the official EU test used to calculate standardised fuel consumption and CO2 figures for passenger cars. It measures fuel, energy consumption, range and emissions. The figures provided are as a result of official manufacturer's tests in accordance with EU legislation. For comparison purposes only. Real world figures may differ. CO2, fuel economy, energy consumption and range figures may vary according to factors such as driving styles, environmental conditions, load, wheel fitment and accessories fitted.
 2) Please check with your local market for features, model range and engine availability as they vary by market.
 3) Jaguar Land Rover is constantly seeking ways to improve the specification, design and production of its vehicles, parts and accessories and alterations take place continually. While every effort is made to produce up-to-date literature, this document should not be regarded as an infallible guide to current specifications or availability, nor does it constitute an offer for the sale of any particular vehicle, part or accessory. Figures are manufacturer's estimates.

